

COBRA

MODEL: GT260C / BC260C / BC330C

COBRA GRASS TRIMMER BRUSH CUTTER OWNER'S MANUAL



BC260C / BC330C

GT260C

Caution

Before using our brushcutter, please read this manual carefully to understand the proper use of your unit.
keep this manual handy.

SAFETY FIRST

Instructions contained in warnings within this manual marked with a  symbol concern critical points which must be taken into consideration to prevent possible serious bodily injury , and for this reason you are requested to read all such instructions care fully and follow them without fail.

■ NOTES ON TYPES OF WARNINGS IN THE MANUAL

▲ WARNING

This mark indicates instructions which must be followed in order to prevent accidents which could lead to serious bodily injury or death.

IMPORTANT

This mark indicates instructions which must be followed, or it leads to mechanical failure, breakdown, or damage.

NOTE

This mark indicates hints or directions useful in the use of the product.

Contents

1.PARTS LOCATION.....	2
2.WARNING LABELS ON THE MACHINE.....	3
3.SYMBOLS ON THE MACHINE.....	4
4.SAFETY PRECAUTIONS.....	4
5.SET UP.....	8
6.FUEL.....	10
7.OPERATION.....	10
8.MAINTENANCE.....	12
9.SPECIFICATIONS.....	15

1.PARTS LOCATION

1.Fuel tank	6.Housing	11.Throttle cable
2.Starter	7.Hanger	12.Outer pipe
3.Air cleaner	8.Handle	13.Safety guard
4.Stand	9.Hale bracket	14.Gear case
5.Engine switch button	10.Throttle lever	15.Trimmer Head/Blade



BC260C / BC330C

- | | | |
|------------------------|-------------------|-------------------|
| 1.Fuel tank | 6.Housing | 11.Throttle cable |
| 2.Starter | 7.Hanger | 12.Outer pipe |
| 3.Air cleaner | 8.Handle | 13.Safety guard |
| 4.Stand | 9.Hale bracket | 15.Trimmer Head |
| 5.Engine switch button | 10.Throttle lever | |

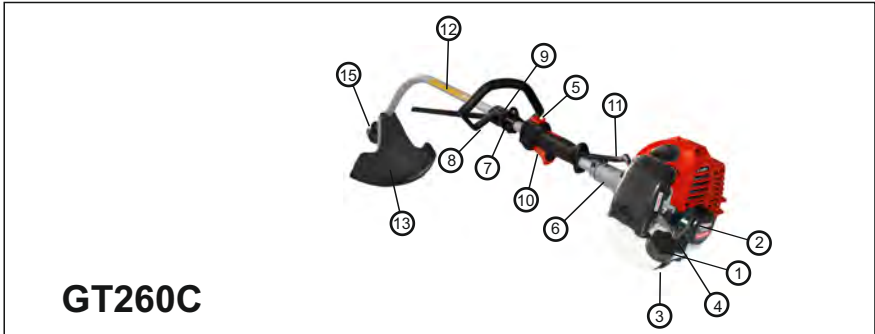

2. WARNING LABELS ON THE MACHINE

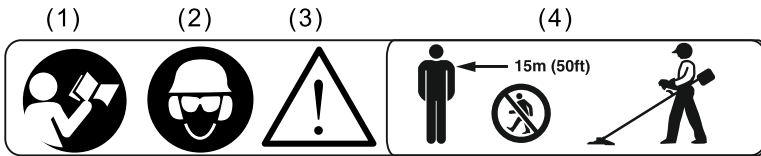

- (1)Read owner’s manual before operating this machine.
- (2)Wear head, eye and ear protection.
- (3)Warning/Attention
- (4)Keep all children, bystanders and helpers 15 meters away from the brush cutter.

IMPORTANT

If warning seals peel off or become soiled and impossible to read, you should contact the dealer from which you purchased the product to order new seals and affix the new seal in the required location.

WARNING

Never remodel your brush cutter.
 We won’t warrant the machine, if you use the remodeled brush cutter or you don’t observe the proper usage written in the manual.

3. SYMBOLS ON THE MACHINE

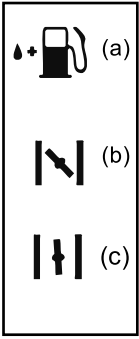

For safe operation and maintenance, symbols are carved in relief on the machine.

According to these indications, please be careful not to make a mistake.

(a).The port to refuel the “MIX GASOLINE”

Position: fuel tank cap

(b).The direction to close the choke

Position: AIR CLEANER COVER

(C).The direction to open the choke

Position: AIR CLEANER COVER

4. SAFETY PRECAUTIONS

■ BEFORE USING THE MACHINE



a. Read this owner’s manual carefully to understand how to operate this unit properly.

b. This product has been designed for use in cutting grass, and it should never be used for any other purpose.

c. You should never use the product when under the influence of alcohol, when suffering from exhaustion or lack of sleep, when suffering from drowsiness as a result of having taken cold medicine, or at any other time when a possibility exists that your judgment might be impaired or that you might not be able to operate the machine properly and in a safe manner.

d. Avoid running the engine indoors. The exhaust gases contain harmful carbon monoxide.

e. Never use the product under circumstances like those described below:

1. When the ground is slippery or when other conditions exist which might make it not possible to maintain a steady posture

2. At night, at times of heavy fog, or at any other times when your field of vision might be limited and it would be difficult to gain a clear view of the area.

3. During rain storms, during lightning storms, at times of strong or gale-force winds, or at any other times when weather conditions might make it unsafe to use this product.

f. When using this product for the first time, before beginning actual work, learn to handling it from a skilled worker.

g. Lack of sleep, tiredness, or physical exhaustion results in lower attention spans, and this in turn leads to accidents and injury.

Limit the amount of time of using the machine continuously to somewhere around 10 minutes per session, and take 10~20 minutes of rest between work sessions. Also try to keep the total amount of work performed in a single day under 2 hours or less.

h. Be sure to keep this manual handy so that you may refer to it later whenever any questions arise.



- I. Always be sure to include this manual when selling, lending or otherwise transferring the ownership of this product
2. Never allow children or anyone unable to fully understand the directions given in this manual to use this brush cutter.

■ WORKING GEAR AND CLOTHING

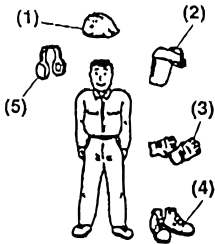

a. When using the product, you should wear proper clothing and protective equipments as follows.

- (1) **Helmet**
- (2) **Protection goggles or face Protector**
- (3) **Thick work gloves**
- (4) **Non-slip-sole work boots**
- (5) **Ear protectors**

b. And you should carry with you.

1. Attached tools and files.
2. Properly reserved fuel
3. Spare blade
4. Things to notify your working area (Tape, warning signs)
5. Whistle (for collaboration or emergency)
6. Hatchet or saw (for removal of obstacles).



c. Never use the product when wearing sandals, or when barefoot.

■ WORKING CONSIDERING HANDLING OF FUEL



- a. The engine of this product is designed to run on a mixed fuel which contains highly flammable petrol. Never store cans of fuel or refill the fuel tank in any place where there is a boiler stove, wood fire, electrical sparks, welding sparks, or any other source of heat or fire which might ignite the fuel.
- b. Smoking while operating the product or refilling its fuel tank is extremely dangerous. Always be sure to keep lit cigarettes away from the product at all times.
- c. When refilling the tank always turn off the engine first and take a careful look around to make sure that there are no sparks or open flames anywhere nearby before refueling.
- d. If any fuel spillage occurs during refueling, use a dry rag to wipe up spills before turning the engine back on again.
- e. After refueling, screw the fuel cap back tightly onto the fuel tank and then carry the product to a spot 3 m or more away from where it was refueled before turning on the engine.

■ THINGS TO CHECK BEFORE USING YOUR BRUSHCUTTER

- a. Before beginning work, look around carefully to get a feel for the shape of the land or grass to be trimmed and whether or not there are any obstacle which might get in the way while working, and remove any

obstacles, which can be cleared away.

b. The area within a perimeter of 15m of the person using the brush cutter should be considered a hazardous area into which no one should enter while the brush cutter is in use, and when necessary yellow warning rope, warning signs should be placed around the work area. When work is to be performed simultaneously by two or more persons. Always check the presence and locations of others so as to maintain a safe distance.

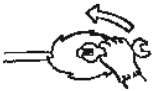

c. Make sure that there are no loose screws or bolts, fuel leaks, ruptures, dents, or any other problems, which might interfere with safe operation. Be especially careful to check that there is nothing wrong with the blades or with the joints by which the blades are attached to the brush cutter.

d. Never use blades that are bent, warped, cracked, broken or damaged in any way.

e. Keep the blade always sharp.

f. Filing the cutting edges, keep the end corner sharp and round the root of the edge.

g. Check the bolt to fasten the blade and be sure the blade turns smoothly without abnormal noise.

■ NOTES ON STARTING THE ENGINE

1. Take a careful look around to make sure that no obstacles exist within a perimeter of 15m or less around brush cutter.

2. Place the body of the brush cutter onto the ground in a flat clear area and hold it firmly in place so as to ensure that neither the blades nor the throttle come into contact with any obstacles when the engine starts up.



3. Place the throttle into the idling position when starting the engine.

4. After starting up the engine, if the blades continue to rotate even after the throttle has been moved fully back, turn off the engine and check the throttle wire and other parts.

■ KICKBACK SAFETY PRECAUTIONS

A dangerous reaction may occur when the spinning blade contacts a solid object in the critical area. It is called kick back, as a result, the operator can lose control of the unit, which can cause serious or fatal injury.

Avoid kickback, observe the safety precautions below strictly.

1. Before beginning work, clear your working area and remove grasses around the obstacles.

2. When using your brush cutter do not grip other parts except the handles.

3. When using your brush cutter always pay attention. Set the machine to idle when necessary.
4. When using your brush cutter do not let the unit get close to your feet or raise the unit above your waist.

■ NOTES ON TRANSPORTATION

1. Make sure the appropriate blade cover is in place.
2. When transporting by car fix the unit firmly using a rope. Do not transport by bicycle or motorcycle because it is dangerous.
3. Never transport the brush cutter over rough roads over long distances without first removing all fuel from the fuel tank, as doing so might cause fuel to leak from the tank.

■ OPERATION SAFETY PRECAUTIONS

1. Grip the handles of the brush cutter firmly with both hands. If you suspend the work, place the throttle into the idling position.
2. Always be sure to maintain a steady even posture while working.
3. Maintain the speed of the engine at the level required to perform cutting work and never raise the speed of the engine above the level necessary.
4. If the grass gets caught in the blade during operation or if you need to check the unit or refuel the tank always be sure to turn off the engine.



5. If the blade touches a hard object like a stone immediately stop the engine and check if something is wrong with the blade. If so replace the blade.
6. If someone calls out while working always be sure to turn off the engine before turning around.



7. Never touch the spark plug or plug cord while the engine is in operation, doing so may result in being subjected to an electrical shock.
8. Never touch the muffler spark plug or other metallic parts of the engine while the engine is in operation or immediately after shutting down the engine. Doing so may result in serious burns.



9. When you finish cutting in one location and wish to continue work in another spot turn off the engine and turn the unit as the blade faces away from your body.

■ MAINTENANCE SAFETY PRECAUTION

1. Perform the maintenance and checking operations described in this manual at regular intervals. If any parts must be replaced or any maintenance or repair work not described in this manual must be performed please contact a representative from the store nearest authorized servicing dealer for assistance.
2. Under no circumstances should you ever take apart the brush cutter or alter it in any way. Doing so might result in the brush cutter becoming damaged during operation or the brush cutter becoming unable to operate properly.

3. Always be sure to turn off the engine before performing any maintenance or checking procedures.
 - . When sharpening removing or reattaching the blade proper tools and equipment to prevent injury.
 - . When replacing blade or any other parts or when replacing the oil or any lubricants always be sure to use nly products or products which have been certified by for use with the brush cutter.

5. SET UP

4

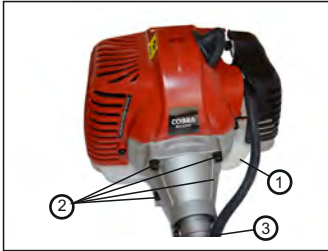

■ ENGINE AND MAIN PIPE

Align the hanger and the fuel tank using attached 4 socket screws secure the connection firmly with equal force.(F1)

- (1) Fuel tank
- (2) Bolt
- (3) Main pipe



■ HANDLE

1.Loosen the 4 bolts on the handle bracket.(F2)
2.Insert the right handle (throttle lever is attached) and the left handle assembly into the bracket and retighten the bolts securely.(F2)

- (1) Handle bracket
- (2) Right handle
- (3) Bolt
- (4) Left handle
- (5) Engine side

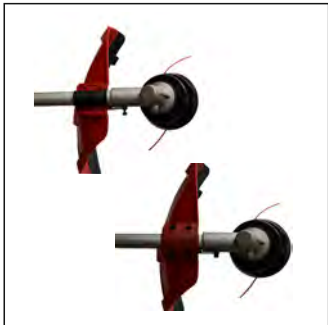

■ SAFETY GUARD

Attach the safety guard to the gear case and fix it with the clamp and 2 bolts (M5*25) securely.(F3)

- (1) Bolt
- (2) Clamp
- (3) Main pipe
- (4) Safety guard



■ THROTTLE WIRE

WARINNG

After fitting up the wire make sure that the throttle cable is put in the throttle lever. If not it is very dangerous because the engines rotate after releasing the throttle.

1. Hook the cable end into the hole of the throttle lever. And set the cable in the lever as shown in the picture.(F4)
2. Wrap the band so as the throttle wire is fixed with the handle.

(1) Hole

(2) Throttle cable

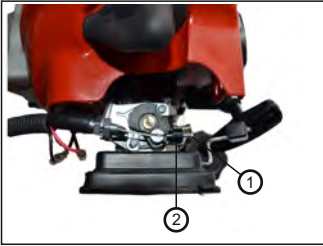

■ ADJUSTING TH THROTTLE CABLE

1. After releasing the throttle lever pull the throttle wire. The normal play is 1 or 2 mm when measured at the carburetor side end.
2. If the play is short or long take off the air cleaner cover loosen the lock nut and adjust the play.(F5)

(1) Adjust nut

(2) Lock nut

■ INSTALLING THE METAL BLADE (F6)

1. Set the inner holder to the gear shaft and burn to fix with the attached L-shaped bar.
2. Put the blade on the inner holder with letters to the gear case and match correctly the hole of the blade to the projection of the inner holder.
3. Set the outer holder to the gear shaft with the hollowed face to the blade.
4. Put the attached bolt cover on the outer holder and secure it with the bolt (left screw) together with the spring washer and the washer.

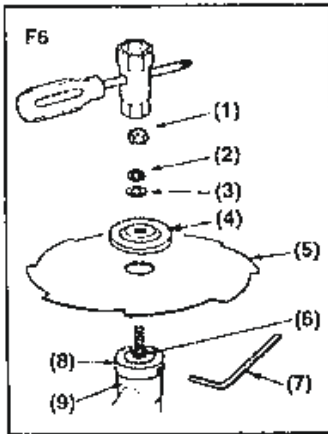

(1) Nut

(2) Spring Washer

(3) washer

(4) Outer holder

(5) Blade

(6) Gear shaft

(7) Bar

(8) Inner holder

(9) Gear case

■ INSTALLING THE NYLON CUTTER(OPTION) (F7)

1. Set correctly the inner holder and the outer holder to the gear shaft.
2. Screws the attached bold (M8 Left) into the gear shaft and secure it with the spanner.
3. Screw the nylon cutter into the bolt by fixing the inner holder with the L-shaped bar and tighten it manually.

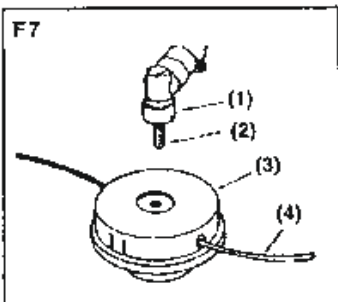

NOTE

Keep bolts and washers to install the blade carefully so as not to lose them.

- (1) Gear Case
- (2) Bolt
- (3) Nylon cutter
- (4) Nylon cord

6.FUEL

WARNING



- ☆ Petrol is very flammable. Avoid smoking or bringing any flame or sparks near fuel.
- ☆ Wipe up all spills before starting the engine.
- ☆ Make sure to stop the engine and allow it cool before refueling the unit.
- ☆ Keep open flames away from the area where fuel is handled or stored.

IMPORTANT

- ☆ Never use oil for 4-cycle engine use or water cooled 2-cycle engine. It can cause spark plug fouling exhaust port blocking or piston ring sticking.
- ☆ Mixed fuels which have been left unused for a period of one month or more may clog the carburetor or result in the engine failing to operate properly. Put remained fuel into an airtight container and keep it in the dark and cool room.

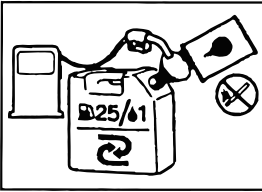

Mix a regular grade petrol (leaded or unleaded alcohol-free) and a quality-proven motor oil for air-cooled 2 cycle engines.

RECOMMENDED MIXING RATIO GASOLINE 25 : OIL 1

7.OPERATION

■ STARTING THE ENGINE

WARNING

- ☆ Before starting the engine inspect the entire unit for loose fittings or fuel leaks and the cutting attachment is properly installed and securely fastened.

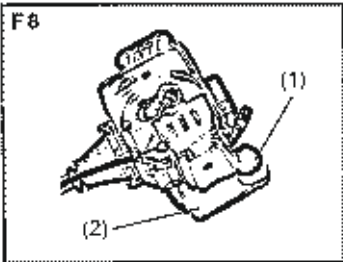

- ☆ Place the unit on a flat firm place. Keep the cutting head clear of everything around it.

1. Turn the cap to the fuel tank to make sure that it is fixed on tightly (F8)
- (1) Cap
- (2) Fuel tank

2. Open the fuel tank cock.(F9)
3. Move the choke lever to the closed position.(F9)

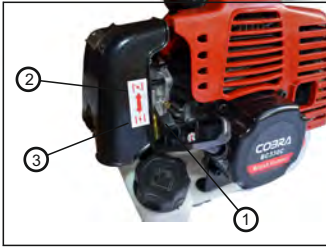

- (1) Choke lever
- (2) Closed position - starting from cold
- (3) Open position - normal running

NOTE

When restarting immediately after stopping the engine move the choke lever to the open position.

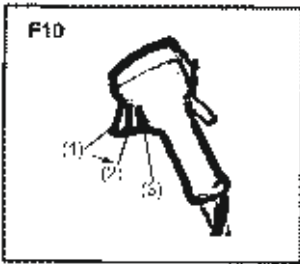

4. Set the throttle lever to the starting position.(F10)

- (1) Idling
- (2) Starting (1/3-1/2 open)
- (3) Full throttle

NOTE

When restarting immediately after stopping the engine move the throttle lever to the idling position.

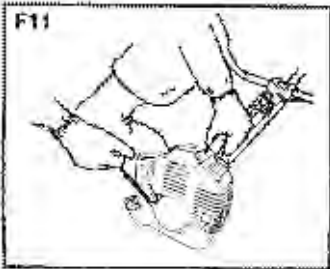

5. While holding the unit firmly pull out the starter rope quickly.(F11)
6. After the engine has started open the choke gradually.
7. Allow the engine to run for 2 to 3 minutes to warm up.

■ STOPPING THE ENGINE

1. Return the throttle lever to the idling position.
2. Push the engine switch button.

■ EQUIPPING THE SHAWL BAND(F12)

1. Equip the attached shawl band.(F12)
2. Turn on the engine return the throttle lever to the lowest speed position and put the shawl band hook to the hanging part of the machine.
3. Adjust the length of the shawl band so that the blade may be parallel to the ground in the working position. In order to prevent stack during operation turn up the extra part of the band from the buckle.

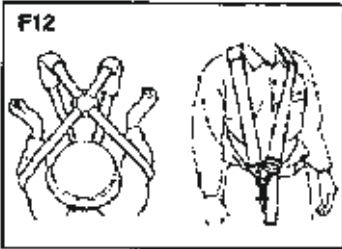

■ CUTTING OPERATION

METAL BLADE USAGE



- ☆ Always cut by guiding the head from your right to left.
- ☆ A metal blade cut best up to the point 1/3 from the edge. Use that area for cutting shrubs tough and thick weeds. For cutting young grass you can use up to 2/3 from the tip of blade.
- ☆ Adjust the engine speed according to the cutting objects. Cut the young grass at middle speed and cut shrubs or tough and thick weeds at high speed.

- (1) For branches and frees
- (2) For grass and weeds
- (3) Direction of cutting
- (4) Direction of rotation

IMPORTANT

Operating at low speed makes it easier for grass weeds or twigs to become caught up in the blades and also it makes the shaft and clutch wear down more quickly.

NYLON CUTTER USAGE

- ☆ Nylon cord consumes large power. Please note that the engine rotation speed in operation should be 50% as large as when using metal blade.
- ☆ Nylon cutter cut grass with the power of cord rotation. If you try to cut grass for the length of cord at one time rotation speed becomes lower due to resistance and you cannot cut well. In case of large resistance get the nylon cutter away from grass once make the rotation speed higher and cut a small amount of grass at one time.
- ☆ If you try to cut grass by swinging the brush cutter in the reverse way (from left to right) scraps fly in the direction away from the body. You can avoid getting your clothes dirty.

8.MAINTENANCE

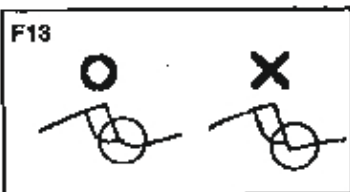

■ BLADE

- ☆ Sharpen each cutting edge and make sure the bottom corner is rounded.(F13)
- ☆ Do not cool the blade with water in case of using grinder. If may cause cracks on blade.

AFTER 25 HOURS OF USE

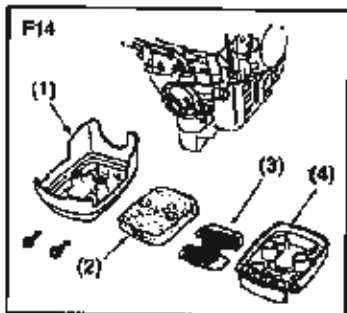

■ AIR CLEANER

Check and clean the filter element in warm soapy water as required. Dry completely before installing. If the element is broken or shrunk replace with a new one. (F14)

- (1) cover
- (2) Element
- (3) screen
- (4) Body

IMPORTANT

A clogged air filter may increase fuel consumption while cutting down the engine power.

And operate the brush cutter without the air filter or with a deformed filter element will quickly ruin the engine.

■ FUEL FILTER

Take the filter out of the fueling port using a small wire hook. Disconnect the filter assembly from the fuel pipe and unhook the retainer to disassemble it. Clean the components with petrol.

IMPORTANT

A clogged fuel filter may cause poor acceleration of the engine.

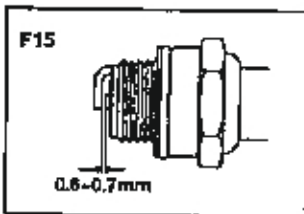

■ SPARK PLUG

Remove and inspect the spark plug and clean the electrodes as necessary with brush.

The spark gap should be adjusted to 0.6 - 0.7 mm. (F 15)

■ INTAKE AIR COOLING VENT

- ☆ Check the intake air-cooling vent and the area around the cylinder cooling fins and remove any waste which has attached itself to the brush cutter.

IMPORTANT

- ☆ Note that failing to do so could cause the muffler to become overheated and that this in turn could cause the brush cutter to catch on fire.

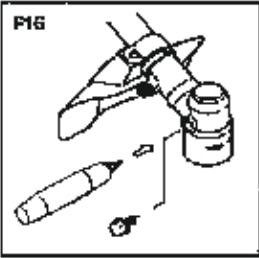

GEAR CASE

Supply multi-purpose grease at every 25 hours of use. Remove the cutter holders to arrange for old grease to exit.(F16)

AFTER 100 HOURS OF USE

■ MUFFLER

1. Remove the muffler insert a screwdriver into the vent and wipe away any carbon buildup. Wipe away any carbon buildup on the muffler exhaust vent at the same time.
2. Tighten all screws bolts and fittings.
3. Check to see if any oil or grease has worked its way in between the clutch lining and drum and if it has wipe it away using oil-free lead-free petrol.
4. Remove the float cabin of the carburetor and clean the inside.

■ ADJUSTING CARBURETOR

IMPORTANT

A wrong adjustment may cause damage to your unit. If the engine does not run well after adjusting the carburetor please contact the shop where you purchased the product.

■ IDLE ADJUSTMENT SCREW (F17)

This is the screw to adjust the engine rotation when the throttle lever is set to the

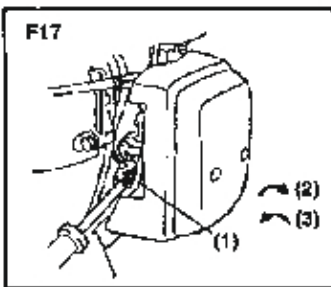

lowest speed position. If you turn right (clockwise), rotation increases and left (counterclockwise) decreases. In case the blade continues to rotate or engine stops when you return the throttle lever completely to the original position make readjustment.

- (1) Idle adjustment screw
- (2) High
- (3) Low

MAINTENANCE BEFORE STORAGE

1. Brushing off dirt from the machine check damage or stack of each part if

you find out abnormalities repair them for the next use.

2. Extract fuel from the tank and loose the drain screw of the float cabin to extract fuel turn on the engine and leave it running until it stops naturally.

3. Remove the spark plug and put in 1-2cc of 2-cycle oil in the engine. Draw the starter rope 2-3 times, set the plug back and stop it at the contraction position.

4. Apply anti-rust oil to the metal parts such as the throttle wire put the cove on the blade and keep it indoor avoiding dampness.

9.SPECIFICATION

Name/Type		Brush cutters			
		BC260	BC330	BC415	BC520
Specification		BC260	BC330	BC415	BC520
Handle Type		Loop	Loop	Both Hands	Both Hands
Power Transmission Method		Automatic centrifugal clutch, spiral gear			
Applied Blade		4-teeth blade, 8-teeth blade, bamboo blade, round saw blade, chip saw, more unit, nylon cutter			
Blade Rotation Direction		Counter clockwise (from operator's view)			
Outward Size(L*W*H)(cm)		182*23*22	183*61*42		
Weight (Kg)		6.0	7.1	7.5	7.9
Engine	Type	Single cylinder air cooling 2-cycle gasoline engine			
	Displacement volume (cc)	25.4	32.6	42.7	51.7
	Carburetor	Diaphragm, Rotary valve		Float, piston valve	
	Starting Method	Recoil starter			
	Stopping Method	Sparking Circuit Primary Short			
	Fuel Used	Lubricating oil mixed gasoline (mixing rate 25:1)			
	Lubricating Oil Used	2-cycle engine oil			
	Fuel tank Capacity (L)	0.6	0.8	1	1

NOTE: This owner's manual is used for upper-listed machines, if slight differences from these machines happen; the substantial machine decides the specification of technology and usage.

Spare parts of working shaft

No.	Name	Quantity	No.	Name	Quantity
1	Gear case assembly	1	43	Down holder	1
2	Retaining ring 26/28	1	44	Screw M5X20	2
3	Retaining ring 10	1	45	Hanger link assembly	1
4	Bearing 6000	3	46	Hanger link	1
5	Little are-shape gear	1	47	Retaining ring 35	1
6	AI-washer5	2	48	Bearing 6202	1
7	Screw M5X10	2	49	Retaining ring 15	1
8	Gear case	1	50	Screw M5X20	1
9	Coniod are-shape big gear	1	51	clutch drum	1
10	Shaft	1	52	Splint A	1
11	Bearing 6002	1	53	Splint B	1
12	Retaining ring 32	1	54	Screw M5X20	1
13	Protection	1	55	Clutch case	1
14	Holder for shaft	1	56	Connector for protection	1
15	Holder for blade	1	57	Rubber bushing	1
16	Holder 2 for blade	1	58	Screw M5	1
17	Left screw M10	1	59	hunger	1
18	Washer 5	2	60	Screw M5X25	1
19	Washer 5	2	61	Screw M5X20	1
20	Bolt M5X25	2	62	Screw M5X20	1
21	Blade	1	63	Screw M5	1
22	Bolt M5X16	4	64	Screw M6X25	1
23	Washer ring 5	4	65	Hunger cap	1
24	Washer 5	4	66	Shoulder strap	1
25	Washer 5	4	67	Throttle line	2
26	Nut M5	4	68	Stop switch's line	1
27	Bolt M5X12	2	69	Wave pipe	1
28	Washer ring	2	70	Screw M5	1
29	Washer	2	71	Nylon wire band	1
30	Screw M5	2	72	Warning mark	1
31	Holder	1	73	Protector	1
32	Plastic protection	1			
33	AI-pipe assembly	1			
34	Oil bearing	5			
35	Transmission shaft	1			
36	AI-pipe	1			
37	Right grip of handle	1			
38	Left grip of handle	1			
39	AI-pipe	2			
40	Up holder	1			
41	Screw M5X25	4			
42	Localizer link	1			



EC-DECLARATION OF CONFORMITY

EC Declaration of Conformity	
We herewith declare,	Cobra Garden Machinery Henton & Chattell Ltd, London Road, Nottingham NG2 3HW United Kingdom
that the following machine complies with the appropriate basic safety and health requirements of the EC Directive based on its design and type, as brought into circulation by us.	
In case of alteration of the machine, not agreed upon by us, this declaration will lose its validity	
Machine Description:	26cc / 33cc Brush Cutter / Grass Trimmer
Machine Type:	Cobra BC260C (PNBC260-3B) / GT260C / BC330C
Displacement	25.4 cm ³
Measured sound power level:	Brush Cutter 89.8 dB(A) Grass Trimmer 92.0 dB(A)
Guaranteed sound power level:	Brush Cutter 110.2 dB(A) Grass Trimmer 112.6 dB(A)
Name of Notified Body	Intertek Testing Services Ltd., Building No 86 1198 Qinzhou Road North Shanghai, 200233
Applicable EC Directives	EC Machinery Directive:2006/42/EC EC Directive of Electromagnetic Compatibility:2004/108/EC EC Directive of noise emission: 2005/88/EC
Applicable Harmonized Standards	EN ISO 11806 EN ISO 14982
Authorized Signature/Date	 Peter J. Chaloner 03-03-2014
Title of Signatory	Managing Director
Name and address of the person authorised to compile the technical file	Cobra Garden Machinery Henton & Chattell Ltd, London Road, Nottingham NG2 3HW United Kingdom

WARRANTY

This product is warranted in accordance with legal regulations for a 24 month period effective from the date of purchase by the first user.

This product will not be covered if used in a commercial application.

This warranty covers all material or production failures, it does not include: defects from normal wear and tear, parts such as, bearings, brushes, cables, air cleaning elements, brake pad, clutch disc, tyre, wheel, recoil starter rope, belts, cutter blades, plugs, lubricant oils and grease or accessories. Damage or defects resulting from abuse, accidents or alterations, natural fading of painted or plated surfaces, sheet peeling and other natural deterioration.

Any damage that occurs from the use of non-genuine Cobra parts will not be covered.

We reserve the right to reject any claim where the purchase cannot be verified or when it is clear that the product was not maintained properly. (Clean ventilation slots, carbon brushes and serviced regularly)

Expenses incidental to the warranty claim that are not covered;

-Compensation for loss of time, commercial loss or rental costs of substitute product.

-Costs incurred for transportation to and from the dealership.

Any damage that occurs from the following will not be covered; exposure of the product to smoke and soot, chemical agents, bird droppings or other animal waste, seawater, sea breeze, salt or other environmental phenomena.

Any damage resulting from operating methods other than those indicated in the owner's manual will not be covered.

Your purchase receipt must be kept as proof for date of purchase. Your un-dismantled mower must be returned to your dealer in an acceptably clean state, accompanied by your proof of purchase.

Please Register Your Product

If your dealer did not collect registration information from you, please take a few minutes and register your purchase with Cobra.

You can register by completing and mailing the registration card that should be in the box or by going online to:
www.cobragarden.co.uk and clicking on Product Registration.

Before using this product, all operators must read this manual